



TRANSPORT DEVICES

small helpers - very strong!



- 
Uplifter GmbH & Co. KG
 Uplifter in Oberaich | Central
 Oberaich 5 | 92543 Guteneck
 +49 9433 20499 0
- 
Uplifter in München | Hallbergmoos
 Zwillingshof 1 | 85737 Hallbergmoos
 +49 9433 20499 0
- 
Uplifter in Sinsheim | Lobbach
 Spitzacker 8 | 74931 Lobbach
 +49 9433 20499 302
- 
Uplifter in Frankfurt/Main | Mömbris
 Handwerkerring 6 | 63776 Mömbris
 +49 9433 20499 302
- 
Uplifter in Düsseldorf | Velbert
 Rosenkamp 13 | 42549 Velbert
 +49 2051 42319 0
- 
Uplifter in Berlin | Oberkrämer
 Breitestr. 59 | 16727 Oberkrämer
 +49 3304 2559350
- 
Uplifter in Hamburg | Seevetal
 Bei den Kämpen 8 | 21220 Seevetal
 +49 4185 79997 0
- 
Uplifter Development and Production
 Schulstraße 16 | 92507 Nabburg
 +49 9433 20499 0
- 
Uplifter in Czech and Slovakia / Prague
 Rabakovská 1624/9 | 10200 Praha 15 - Hostivař
 +420 230 234 500
- 
Uplifter in Poland / Warsaw
 5 Przeclawska St. | 03-879 Warsaw
 +48 22 618 27 71

WE ARE HERE FOR YOU!



More applications in the Facebook picture gallery



UPT150

UPT250

UPT400

UPT400

Transport | Uplifter



Load capacity	400 kg
Suction disc quantity*	6 pieces
Curved panes	✗
Side shift	✓
Tilt and incline	✓
Dead weight max.	425,0 kg
Height	1,90 m
Width	0,69 m
Tilt angle	+8° to -18° electrical
Swivel	90°

* with AA batteries

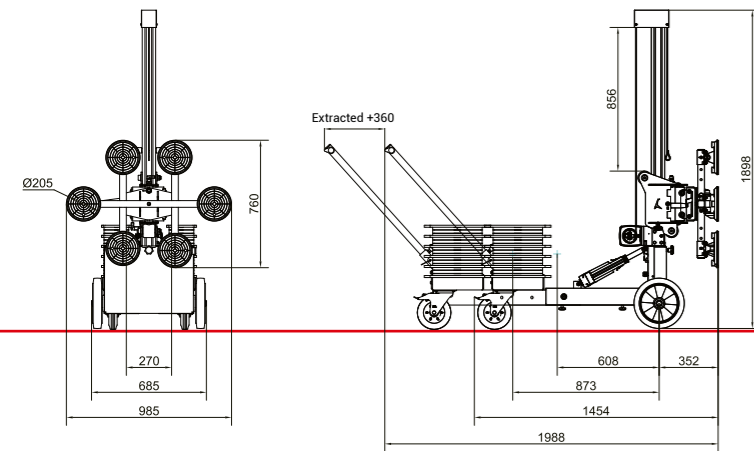

TIP
If the vacuum drops below approx. -0.6 bar, the OTTOvac automatically sucks up to a maximum vacuum of approx. -0.75 bar.

UPT250

Transport | Uplifter



Load capacity	250 kg
Working height max.	ca. 1,7 m Center vacuum cross
Indoor	✓
Outdoor suitable	✗
Dead weight*	240 - 245 kg
Length	1,90 m
Wide	0,72 m
Height	1,98 m
Accessories	electric winch, downward inclined extension, forward extension, adapter for tipping up, side shift, bracket incl. electric suction cups

*depending on equipment

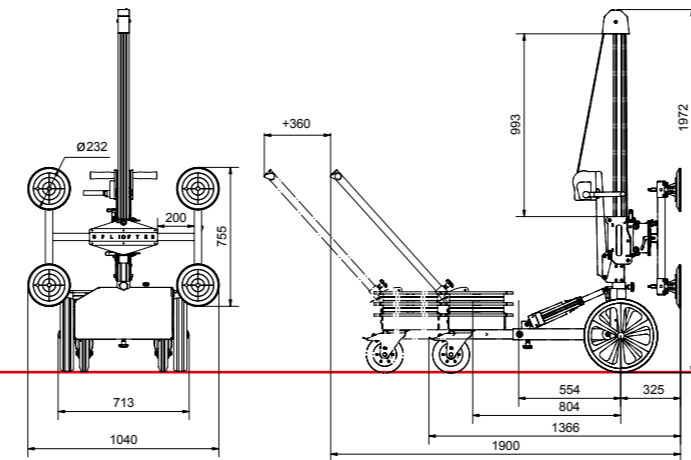

UPT 250

UPT150

Transport | Uplifter



Load capacity	150 kg
Working height max.	ca. 1,7 m Center vacuum cross
Indoor	✓
Outdoor suitable	✗
Dead weight*	69 kg
Length	1,75 m
Wide	0,71 m
Height	1,98 m
Accessories	side shift, downward extension, downward inclined extension, forward extension, holder incl. electric suction cups

*depending on equipment

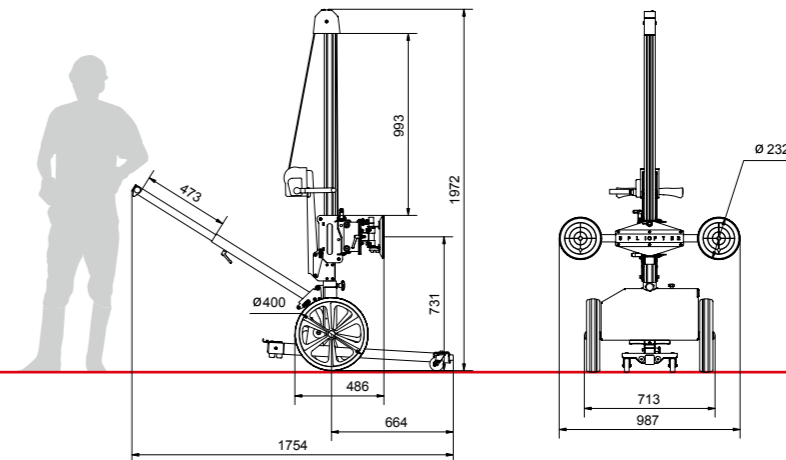

TIP
Optionally, the UPT 150 is also available with electric hand vacuums. This enables the suction of glass, metal, plastic, wood, tiles, concrete, sheetrock and other rough surfaces.

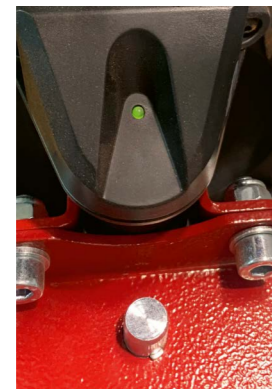

Variable suction pad positioning for different formats or to be able to compensate for openings such as windows.

Removable weights for easier transport.



See the detailed application on our YouTube channel.

A **tipping unit** is available as an accessory and allows **doors, tiles and panels** to be transported as well as assembled in one step.



Quickly dismantled into individual parts, the UPT250 even fits into a car and can be transported to hard-to-reach areas.



UPT 250



See the detailed application on our YouTube channel.

A **tilting unit** is available as an accessory and enables the transport of **doors, tiles and sheet goods** as well as assembly in one step.



TIP
Optionally, the UPT250 is also with electric hand vacuums available. This enables the suction of glass, metal, plastic, wood, tile, concrete, sheetrock, and other rough surfaces.

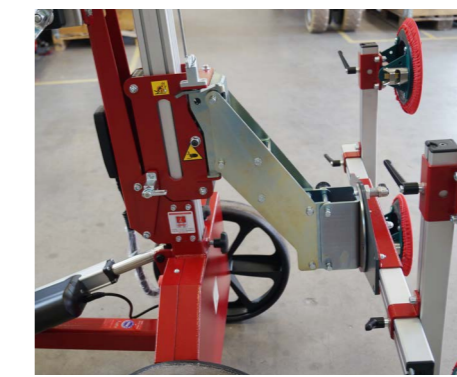

The extension diagonally downwards enables narrow discs to be accommodated

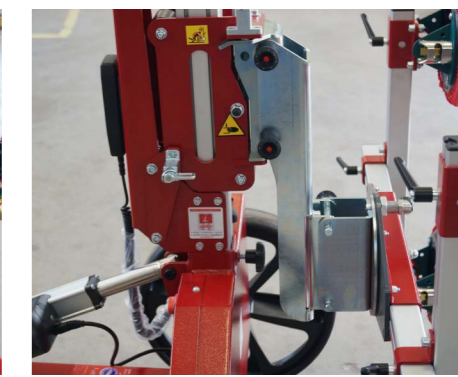

Extensions and side shift are available as accessories



You can find interesting videos with **application areas** on YouTube. Subscribe to our channel to learn more about the possibilities of our machines. From **instruction videos** to construction site applications, it's all here.