



LEADCNC

Product Information

Serial No: 1

Name: Intelligent Buffer Station

Model: LD-QTK



- Designed to stock complete sets of machined profiles for windows and doors.
- Equipped with a stable, multi-tier racking system for horizontal storage of finished aluminum profiles.
- Profile loading and allocation are performed via an escalator, ensuring precise positioning using servo motors.
- Storage space accommodates up to 8 profiles with a depth of 900 mm.
- The buffer station features 25 layers, offering storage for up to 50 window frame stiles or sashes (customizable).
- Finished profile storage is organized by production lots, ensuring compatibility with complete window assemblies.
- Supports remote online maintenance and commissioning services.



LEADCNC

Name: Intelligent Buffer Station

Model: LD-QTK

Product Specification

Machining Specifications	Parameter Value
Max. Profile Cross-Section	H= 150mm, L=300-6,000mm
Maximum Storage Width	Accommodates 8 pieces when the width is 80mm and the depth is 900mm.
Axis	4
Number of Storage Layers	Dual storage with 25 layers; accommodates 50 slots for profiles \leq 3,000mm.

General Parameters	Parameter Value
Power supply	400V/50Hz
Power	10kW
Pressure	0.5-0.8Mpa
Gas consumption	50L/min
Weight	10,300KG
Overall dimensions	11,450×3,350×6,350mm (including workbenches on both sides)

LEADCNC Machinery Co., Ltd

www.leadcnc.com

The right to make technical alterations is reserved.



LEADCNC

Name: Intelligent Buffer Station

Model: LD-QTK

Product Specification

LAYOUT

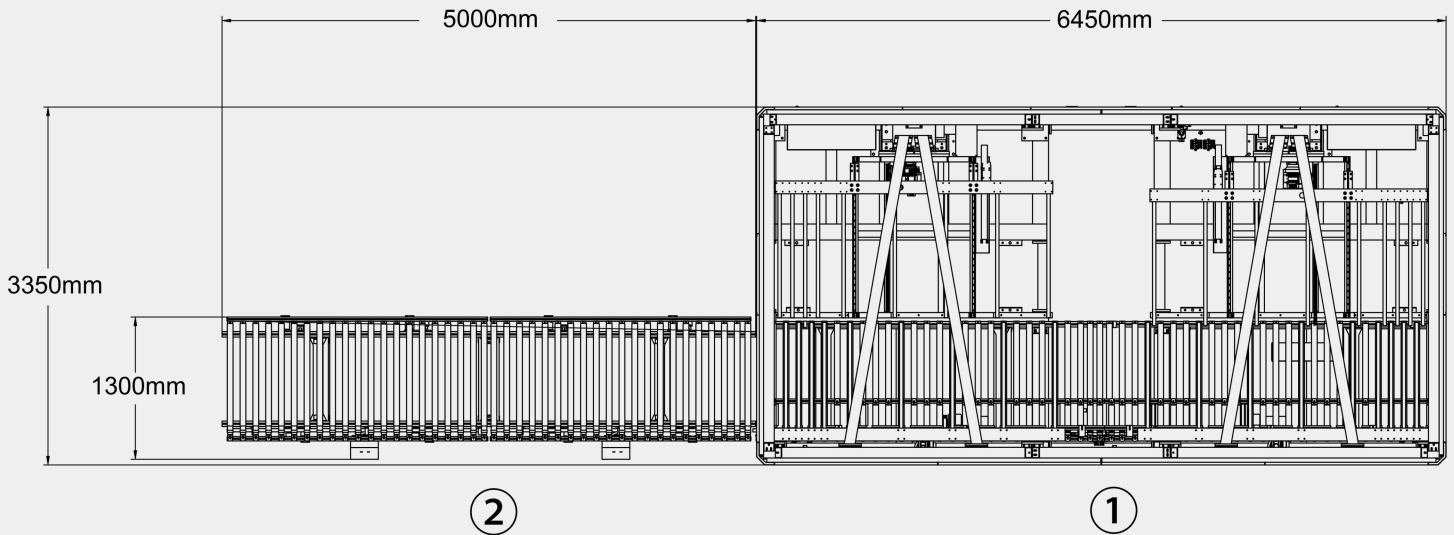

- ① Semi-finished Profile Storage Area
- ② Semi-finished Profile Dispatch Area

LEADCNC Machinery Co., Ltd

www.leadcnc.com

The right to make technical alterations is reserved.